

10'30" 10'35"

Handwritten musical notation for the first system. The staff contains notes and rests. Above the staff, time signatures are written: 16, 4/16, 1/32, 2/16, 1/16, 4/16, 1/16, 1/32, 2/16, 1/16, 3/16, 6/16. Dynamic markings include fff, sfz, p, mp, and pp.

11'55" 11'59"

Handwritten musical notation for the second system. The staff contains notes and rests. Above the staff, time signatures are written: 16, 4/16, 3/32, 4/16, 1/32, 3/32, 1/32, 4/16, 3/32, 1/16. Dynamic markings include p, ppp, pp, fff, and p.

* slow tremolo articulated in the throat
 ** tongue only, minimal air
 *** air noise at fingered pitch.

13'40" 13'43"

Handwritten musical notation for the third system. The staff contains notes and rests. Above the staff, time signatures are written: 3/16 [Finger], 3/32, 6/16, 1/16, 3/16 [tongue], 4/16, 3/16 [res.]. Dynamic markings include ppp, pp, and p.

15'05" 15'09"

Handwritten musical notation for the fourth system. The staff contains notes and rests. Above the staff, time signatures are written: 2/16, 1/16, 6/16, 3/16, 8/16, 1/16, 3/16. Dynamic markings include ppp.

Preview File Only

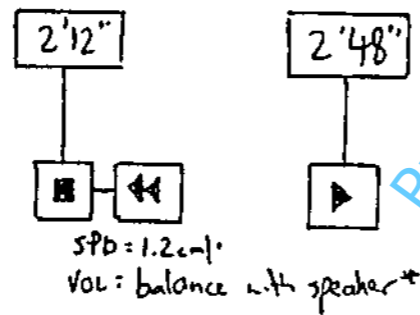
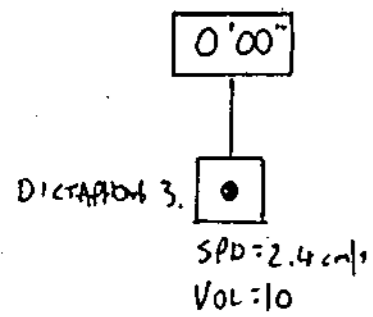
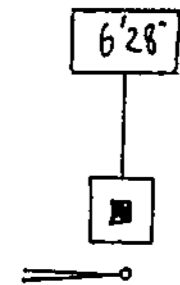
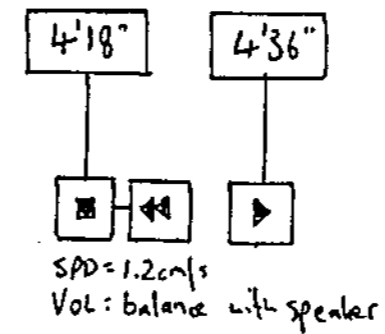
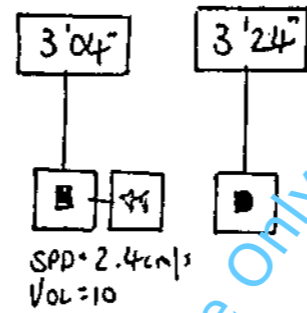
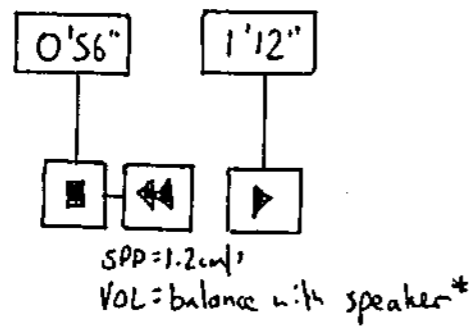
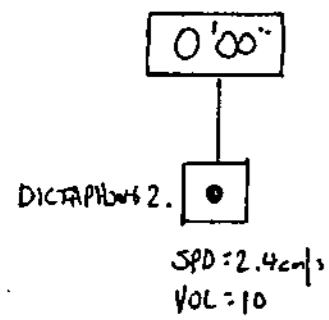
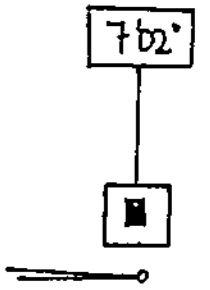
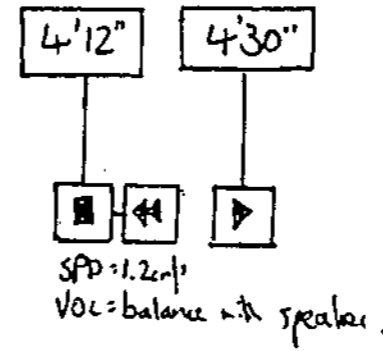
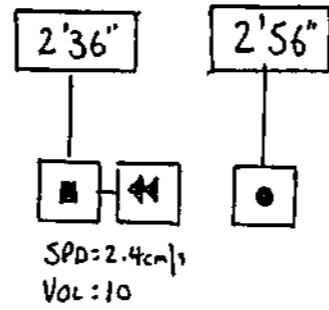
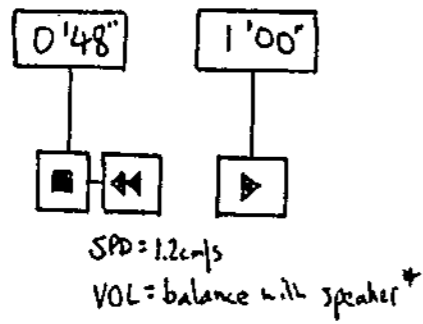
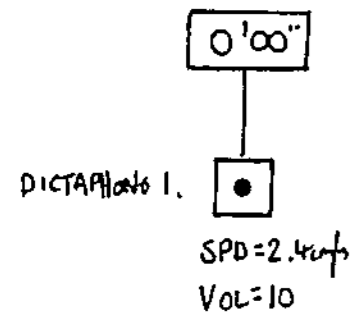

Preview File Only

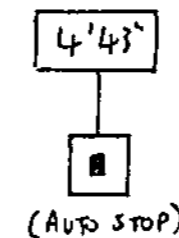
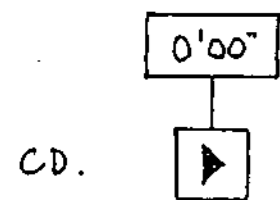
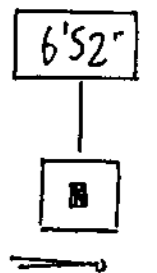
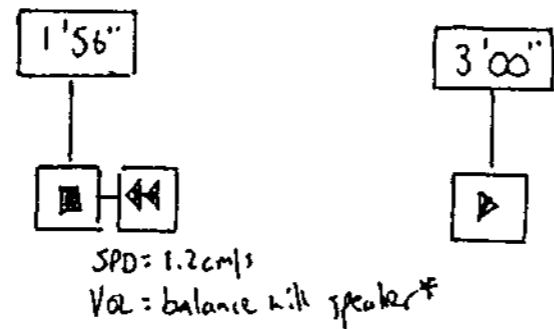
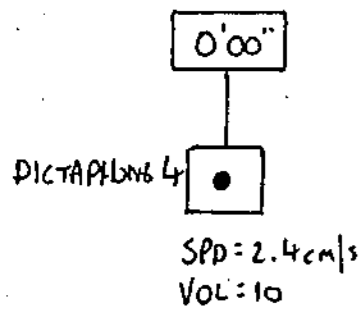
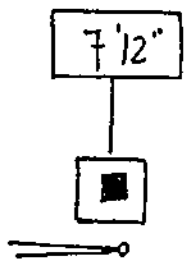

*adjust dictaphone volume during playback to balance sound from speaker. When CD has stopped, balance with other dictaphones.

#[unassigned]
clarinet (version for Apartment House, HCMF 2002)

James Sanders

0'00" START CD.

0'31" 0'35"

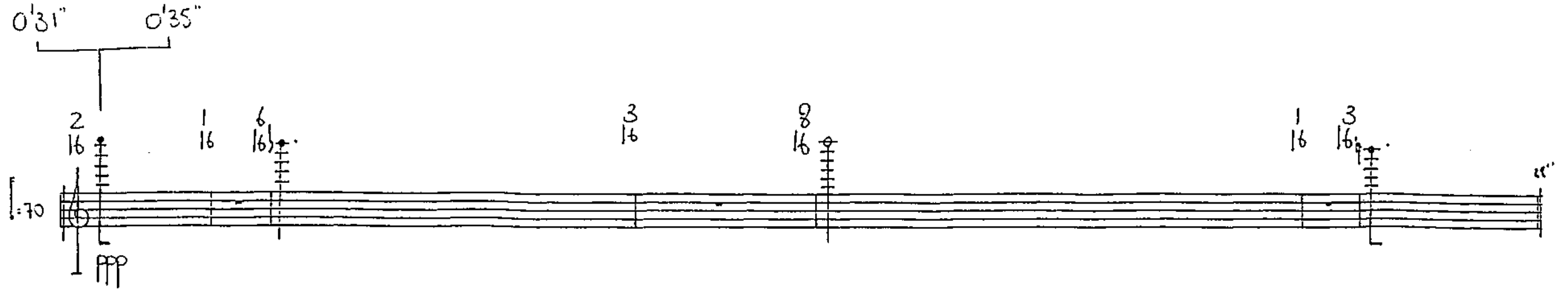

2/16, 1/16, 6/16, 3/16, 8/16, 1/16, 3/16

ppp

1'13" 1'53"

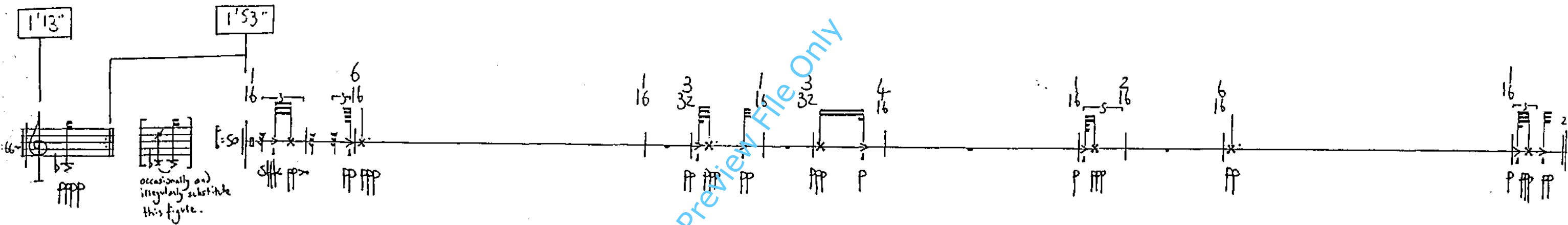

6/16, 1/16, 3/32, 1/16, 3/32, 4/16, 1/16, 2/16, 6/16, 1/16, 2

ppp, pp, pp, p, p, pp, pp

occasionally and irregularly substitute this figure.

2'36" 3'24"

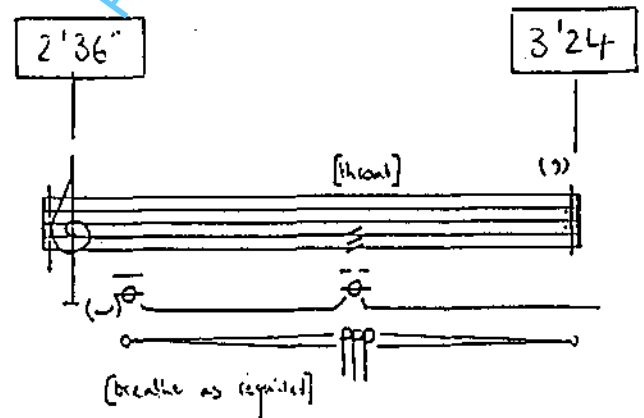

[breath]

(3)

[breathe as required]

3'45" 3'49"

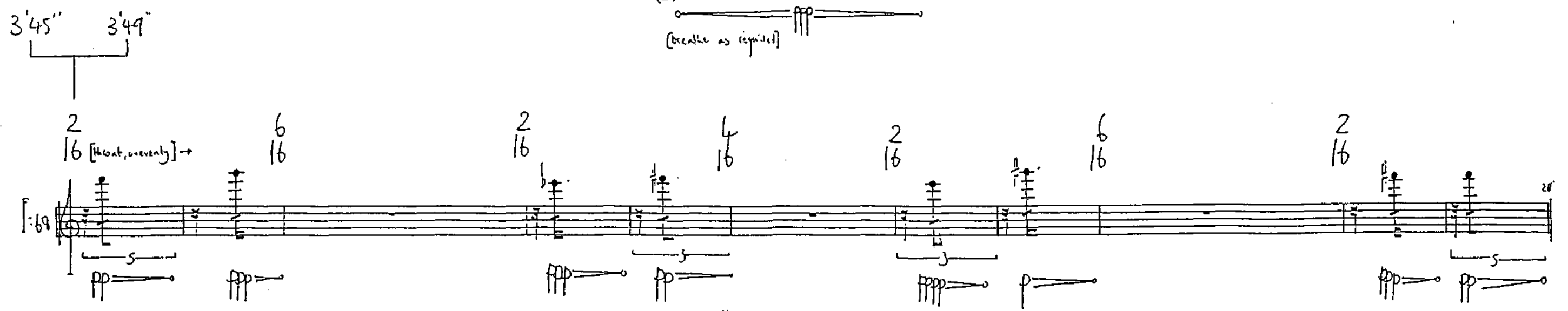

2/16 [breat, unevenly] → 6/16, 2/16, 4/16, 2/16, 6/16, 2/16

pp, ppp, pp, ppp, p, pp, pp

#[unassigned]

auxiliary 2 [version for Tania Chen, John Lely & James Saunders, The Warehouse]

James Saunders

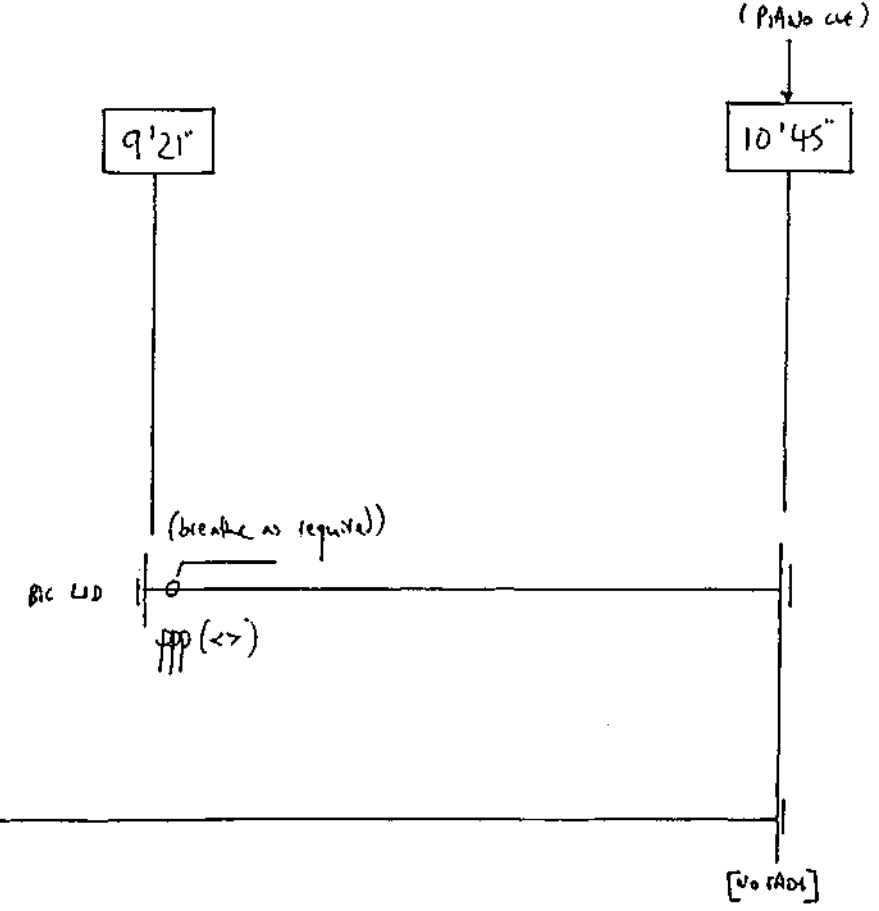
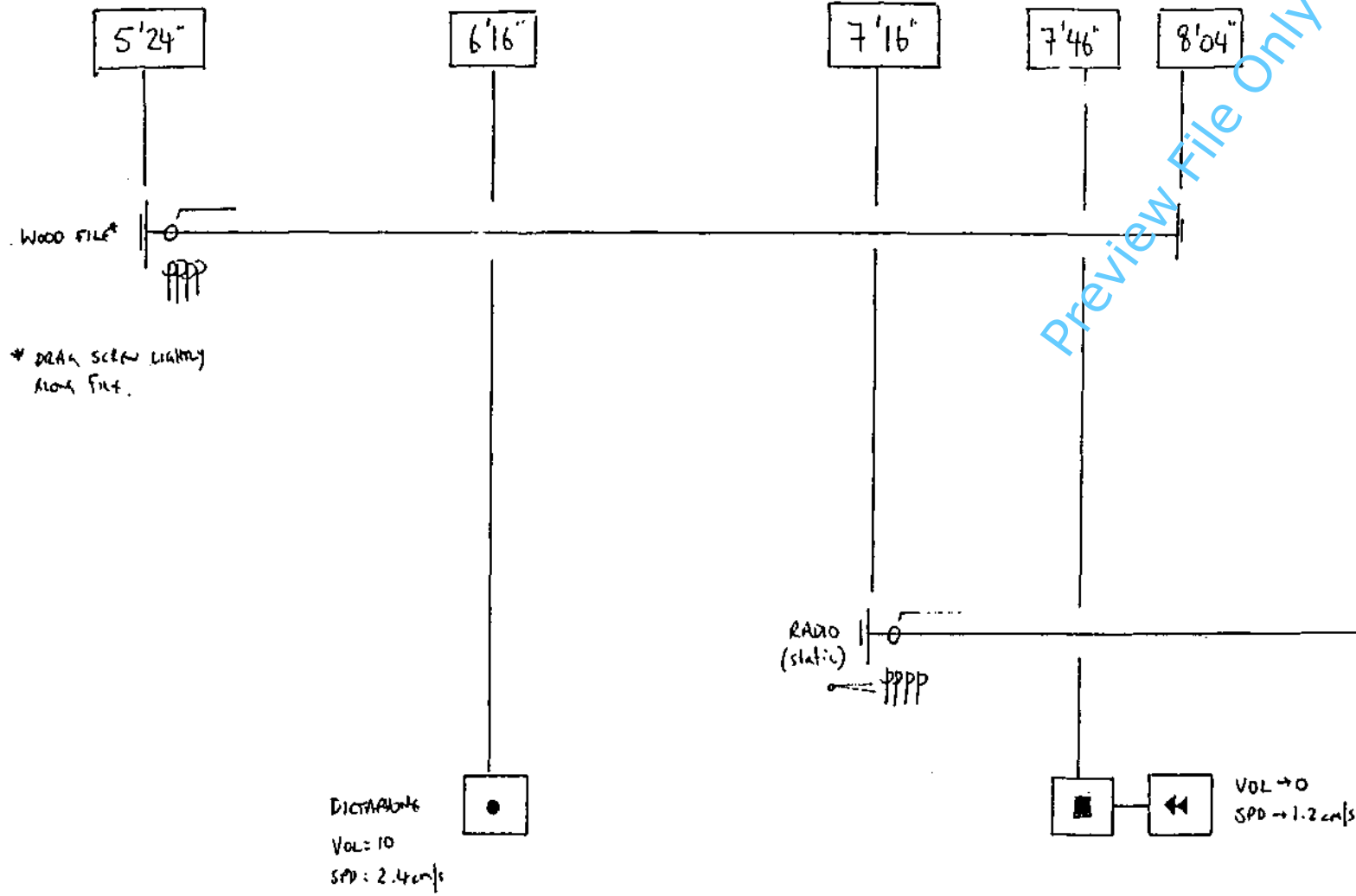
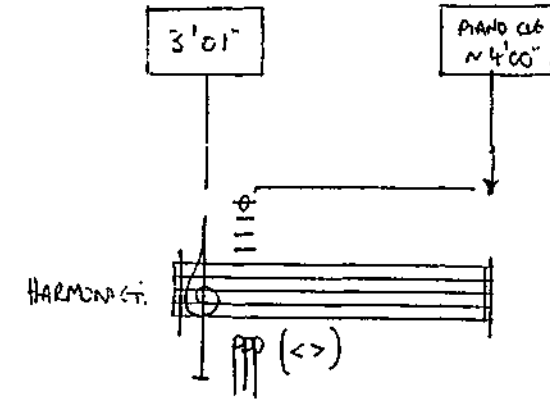
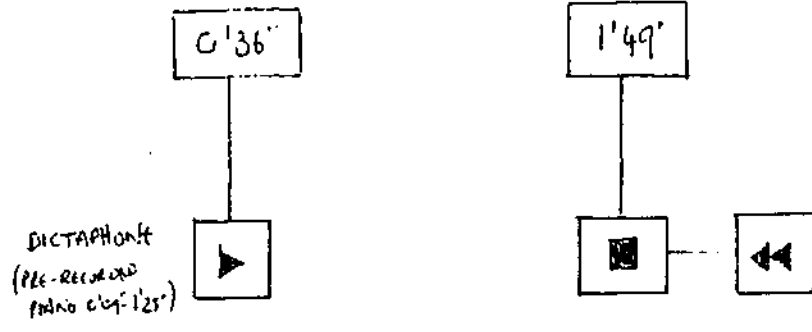

2'21" 2'25"

Handwritten musical score for a string instrument, likely a violin or viola. The score is written on a single staff with a treble clef and a key signature of one flat (B-flat). The tempo is marked as $\text{♩} = 52$. The piece is divided into two sections: the first section is 2'21" long and the second is 2'25" long. The score includes various musical notations such as triplets, slurs, and dynamic markings like *ppp*. There are also performance instructions like "x10" and "x8" above certain notes. A second staff below the main staff shows a tremolo effect with a wavy line and a note, with the instruction "*balance pitch with mechanism noise" written below it.

Preview File Only

3'45" 3'49"

Handwritten musical score for a string instrument, continuing the piece from the previous page. The score is written on a single staff with a treble clef and a key signature of one flat (B-flat). The tempo is marked as $\text{♩} = 66$. The piece is divided into two sections: the first section is 3'45" long and the second is 3'49" long. The score includes various musical notations such as slurs, accents, and dynamic markings like *ppp*. There are also performance instructions like "x" and "x10" above certain notes. A second staff below the main staff shows a tremolo effect with a wavy line and a note, with the instruction "4'07'" written above it.

(cont.)

Handwritten musical score for the first system, featuring a treble clef and a key signature of one flat. The time signature changes from 3/4 to 2/4, then 2/8, 4/4, 2/4, and finally 3/4. The score includes a double bar line with a repeat sign and a fermata. A dynamic marking of *ppp* is present. A box labeled "L.M." is in the top left corner.

Handwritten musical score for the second system, featuring a treble clef and a key signature of one flat. The time signature is 4/4. It includes a double bar line with a repeat sign and a fermata. A dynamic marking of *ppp* is present. A box labeled "L.M." is in the top left corner.

Annotations include: "(join to previous music)", "occasionally substitute this figure, with 1-5 accented articulations, change bow direction as needed.", and "(continue until 4'36-40)".

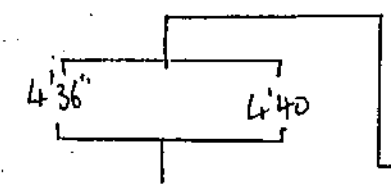

Handwritten musical score for the third system, featuring a treble clef and a key signature of one flat. The time signature is 4/4. The score includes a double bar line with a repeat sign and a fermata. A dynamic marking of *ppp* is present. A box labeled "L.M." is in the top left corner.

Handwritten musical score for the fourth system, featuring a treble clef and a key signature of one flat. The time signature is 4/4. It includes a double bar line with a repeat sign and a fermata. A dynamic marking of *ppp* is present. A box labeled "L.M." is in the top left corner.

Annotations include: "(join to previous music)", "ca. 6600", "occasionally substitute a 1-5 beat rest.", and "6'49'".