

Paul McGuire

PERCUSSION

QUARTET

(2015)

PARTS
(FOR LIVE PERFORMANCE)
+
SCHEMATIC

PARTS
(FOR LIVE PERFORMANCE)

PERFORMANCE NOTES

Instrumentation

- Percussion 1 (Prepared Floor Tom)
- Percussion 2 (Prepared Acoustic Guitar)
- Percussion 3 (Prepared Acoustic Guitar)
- Percussion 4 (Prepared Floor Tom)

Duration: ca. 11 minutes

This piece does not require a conductor. Instead, the performers should all follow the audio guide track played through their earphones, which includes a metronome beating at a tempo of $\text{♩} = 140$ and recorded spoken cues (see General Notation for more details).

The performers should read from their individual parts (see General Notation). The schematic is only intended as a brief summary of the events that take place during the piece.

The instruments should all be amplified (see Technical Setup for more details).

Stage Setup (excluding lighting)

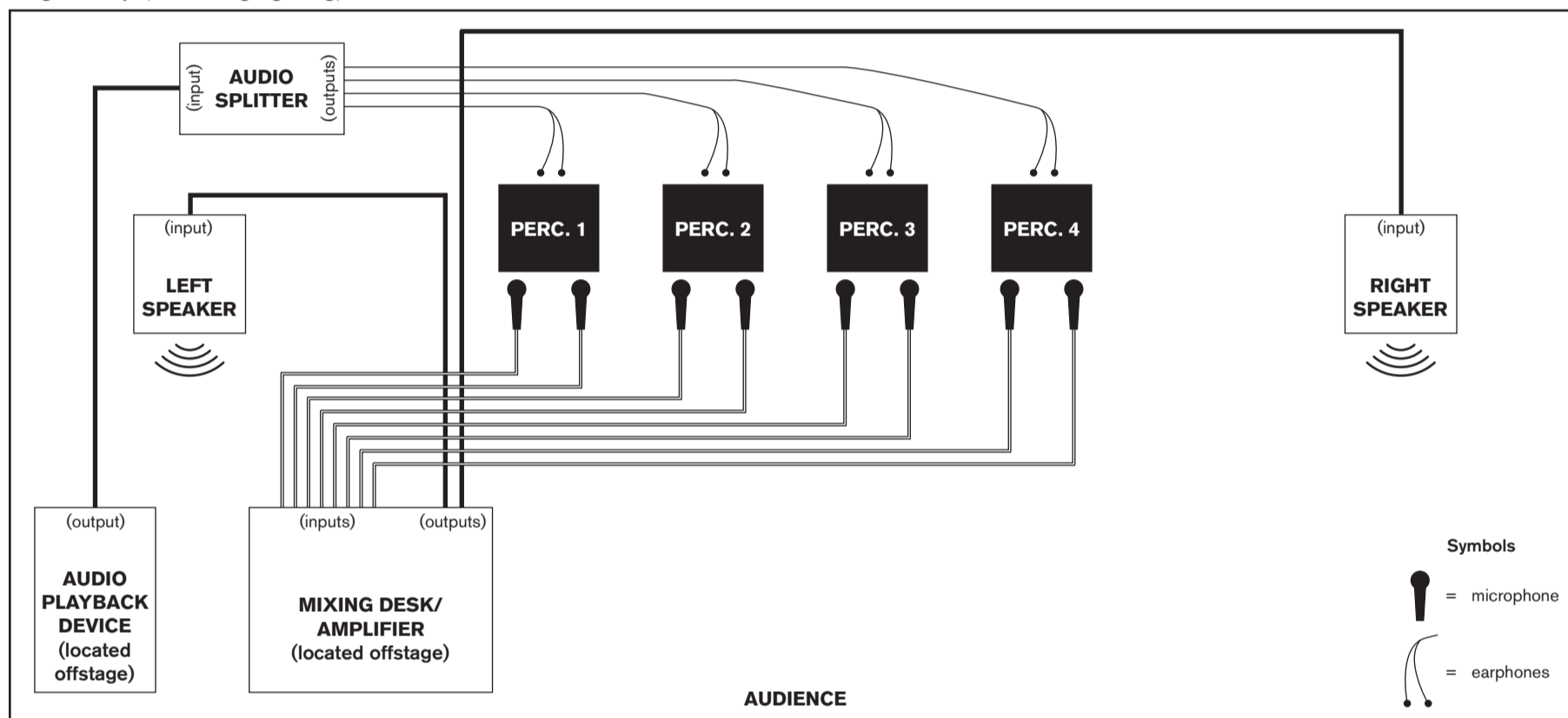

Percussion 1 Setup

The performer should be seated and should wear a pair of earphones (plugged in to the audio splitter) throughout the performance.

The performer is required to play a 14" x 14" (ca. 36 cm x 36 cm) floor tom with a coated top head. This floor tom should match that used for the Percussion 4 part in dimensions, materials and tuning. The floor tom should be prepared with a tea towel that should be draped flat over the top head, completely covering it. From the beginning of the piece, a grenadine clave should be placed on the centre of the tea towel-covered top head, lying horizontally from the performer's perspective (see fig. 1). The clave is removed later in the performance.

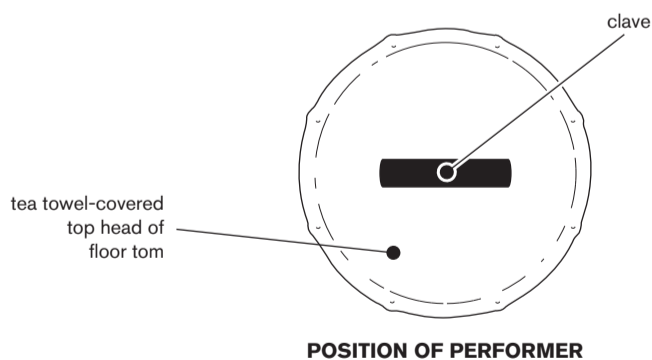

Fig. 1: Placement of tea towel and clave on floor tom (Percussion 1).

The performer is required to have 1 x pair of earphones (as mentioned above), 2 x soft yarn mallet and 1 x wooden drum stick.

Percussion 2 Setup

The performer should be seated and should wear a pair of earphones (plugged in to the audio splitter) throughout the performance. The guitar should be laid string side up across their lap, whereby string IV is the string located closest to them.

The performer is required to play an acoustic steel-stringed guitar. The guitar should have a traditional wooden back and sides (as opposed to a composite synthetic bowl used on some guitars) and should match that used for the Percussion 3 part in terms of dimensions, materials and tuning (both instruments should be tuned to the standard guitar tuning). Although no definite pitches are used in this piece, the tuning of the strings affects the tone of the guitar during Section A and Section B. The strings should be prepared with a ca. 8 cm x 2 cm cylinder of adhesive-tack (e.g. Blu-Tack), firmly placed across the strings, muting them precisely 6.5 cm from the bridge (see fig. 3). Extra care should be taken to ensure string I is particularly thickly wrapped in the adhesive-tack mute in order for the string not to break free from it during Section 2.

(Continued on the next page).

PERFORMANCE NOTES (CONTINUED)

Percussion 2 Setup (continued)

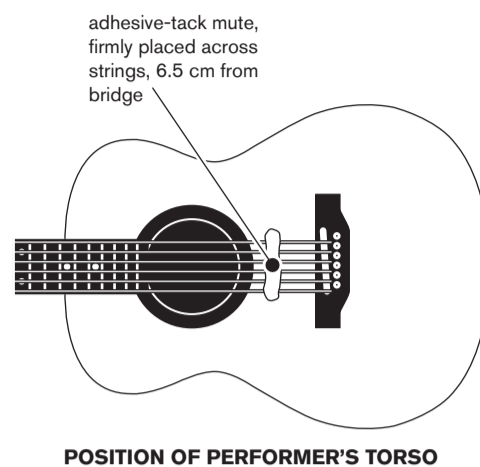

Fig. 2: Placement of adhesive-tack on guitar strings (Percussion 2).

The performer is required to have 1 x pair of earphones (as mentioned above) and 1 x plastic plectrum.

Percussion 3 Setup

The performer should be seated and should wear a pair of earphones (plugged into the audio splitter) throughout the performance. The guitar should be laid string side up across their lap, whereby string IV is the string located closest to them.

The performer is required to play an acoustic steel-stringed guitar. The guitar should have a traditional wooden back and sides (as opposed to a composite synthetic bowl used on some guitars) and should match that used for the Percussion 2 part in terms of dimensions, materials and tuning (both instruments should be tuned to the standard guitar tuning). Although no definite pitches are used in this piece, the tuning of the strings affects the tone of the guitar during Section A and Section B. The strings should be prepared with a ca. 8 cm x 2 cm cylinder of adhesive-tack (e.g. Blu-Tack), firmly placed across the strings, muting them precisely 6.5 cm from the bridge (see fig. 3). Extra care should be taken to ensure string I is particularly thickly wrapped in the adhesive-tack mute in order for the string not to break free from it during Section 2.

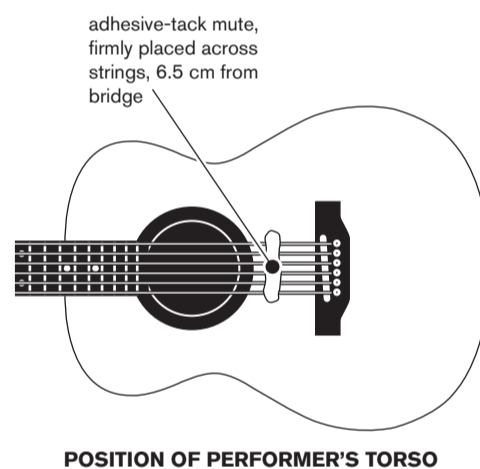

Fig. 3: Placement of adhesive-tack on guitar strings (Percussion 3).

The performer is required to have 1 x pair of earphones (as mentioned above) and 2 x plastic plectrums.

Percussion 4 Setup

The performer should be seated and should wear a pair of earphones (plugged into the audio splitter) throughout the performance.

The performer of this part is required to play a 14" x 14" (ca. 36 cm x 36 cm) floor tom with a coated top head. This floor tom should match that used for the Percussion 1 part in dimensions, materials and tuning. The floor tom should be prepared with a tea towel that should be draped flat over the top head. The tea towel should be folded back, away from the performer, so that ca. 2/3 of the top head is covered, with the uncovered part located just in front of the performer (see fig. 4). The tea towel is unfolded later in the performance.

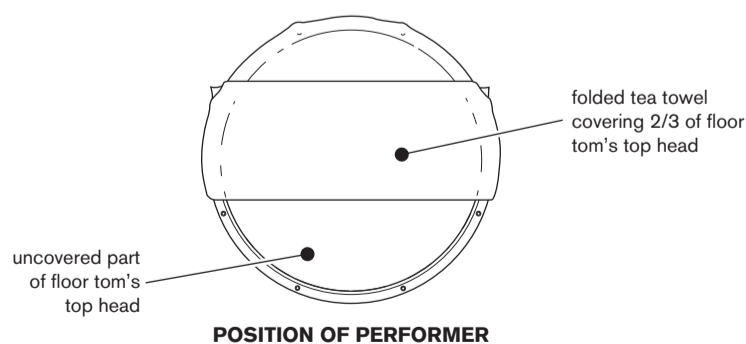

Fig. 4: Placement of tea towel and clave on floor tom (Percussion 4).

The performer is required to have 1 x pair of earphones (as mentioned above), 1 x soft yarn mallet and 1 x wooden drum stick.

PERFORMANCE NOTES (CONTINUED)

Technical Setup

Audio Guide Track

The performers' audio guide track should be played on an audio playback device located offstage, and should be triggered by an engineer to begin the piece. The playback device should be output to an audio channel splitter (which may be located onstage) with at least four output channels. Each of the performers' earphones should be connected to one of the channel splitter's outputs. The performers will likely need to use cable extensions so that their earphone cables can reach the channel splitter with plenty of slack. The audio guide track should be loud enough that the performers can comfortably hear both the audio track and the sounds of their actions. The playback device should not be output to any loudspeakers. During the quiet sections (the opening sixteen bars, Section G and the closing sixteen bars), the engineer should not turn down the performers' guide audio track, as it is intended that the sound of the beating metronome be faintly audible to the audience through the performers' earphones.

Amplification

Each instrument should be close miked (at a distance of ca. 30 cm) from above, preferably in stereo and with a pair of condenser microphones. The engineer should ensure that the volume of all instruments is equally balanced, which may mean turning up the gain on the Percussion 2 and Percussion 3 channels, as the floor toms will likely project more loudly than the guitars. The overall signal should output in stereo to a pair of large loudspeakers, located either side of the performance area. Percussion 1 and Percussion 2 should both be panned to the 10 o'clock position in the stereo field, while Percussion 3 and Percussion 4 should both be panned to the 2 o'clock position. This should ensure a relative stereo balance at all times. The overall volume should be quite loud, with a small amount audible hiss, as if to recreate the experience of hearing music in a nightclub.

Performance Space

The performance should take place indoors, in a sparse, darkened space. The audience may be standing or seated. If there are windows in the space, these should be covered so that no natural light or street lighting enters. The performers should use gooseneck lamps to light their scores and the only other light source in the space, aside from any necessary emergency exit or equipment lighting, should be directed towards the performers. This lighting should be dim, static, and tinted either red or blue. If available, strobe lighting may also be used in time with the music (i.e. strobing in semiquavers at a tempo of $\downarrow = 140$), however if used, the audience should be warned about the strobe lighting before the performance. The overall atmosphere of the performance should feel similar to that of a rave taking place in the early hours of the morning.

General Notation

This piece is divided into eight sections (Section A–Section H), each of which consists of a repeated one bar loop in one or two parts, played by two or three performers. Rhythmically, all loops are comprised of relentless semiquavers played at a tempo of $\downarrow = 140$. As the material is repetitive, rather than having identical bars written in full over and over again across multiple pages, only the first bar of each section is notated. This notation, which consists of a description of the gesture, a labelled diagram, notated rhythmic material and other information, is contained in a box (see fig. 5). In essence, each performer's part functions as a cue sheet. Because of this approach to notation, there is no full score.

Fig. 5: Example showing how each section is notated (Percussion 2, Section F).

In order to play with as much rhythmic precision as possible, the performers follow an audio guide track which is played through their earphones. This audio guide track contains a metronome beating at the tempo of the piece, along with recorded spoken cues. Two bars before each section begins, the recorded voice announces the name of that section over the metronome, and on the following bar, that section is counted in. For example on bar 15, the recorded voice announces "Section A in...", and on bar 16 the voice gives a one bar count in (i.e. "one two three four") to bar 17, where Section A begins. The engineer triggers the audio guide track off stage at the beginning of the piece.

PERCUSSION QUARTET

PART FOR PERCUSSION 1 (PREPARED FLOOR TOM)

Paul McGuire

$\text{♩} = 140$

PRECISE AND MECHANICAL, AS IF PLAYED BY A DRUM MACHINE.
THE PERFORMERS SHOULD BE AS EXPRESSIONLESS AND AS MOTIONLESS AS POSSIBLE THROUGHOUT.

BEGINNING

An engineer off stage should begin the piece by triggering the performers' audio guide track.

The piece starts with sixteen bars where all performers are silent, while the metronome plays on the audio guide track through their earphones. Here, one should sit still with one's hands resting on the top head of the floor tom. On bar 15, a recorded voice on the audio guide track announces "Section A in..." over the metronome, and on bar 16 the voice gives a one bar count in to bar 17, where Section A begins. All subsequent sections are cued in this way.

SECTION A

Rest while Percussion 2 and Percussion 3 play.

While holding a soft yarn mallet in each hand, sit still and silently with one's hands resting on the top head of the floor tom.



SECTION B

Rest while Percussion 2 and Percussion 3 play.

While holding a soft yarn mallet in each hand, sit still and silently with one's hands resting on the top head of the floor tom.



SECTION C

Rest while Percussion 2 and Percussion 3 play.

While holding a soft yarn mallet in each hand, sit still and silently with one's hands resting on the top head of the floor tom.



SECTION D

Rest while Percussion 2, Percussion 4 and, initially, Percussion 3 play.

While holding a soft yarn mallet in each hand, sit still and silently with one's hands resting on the top head of the floor tom.



PART FOR PERCUSSION 1 (PREPARED FLOOR TOM)

SECTION E

With Percussion 3.

Beat the curved surface of the clave, ca. 2 cm away from both ends, on the tea-towel covered top head of the floor tom with the soft yarn mallets.

Avoid letting the clave bounce on the top head as this will result in an inconsistent sound.

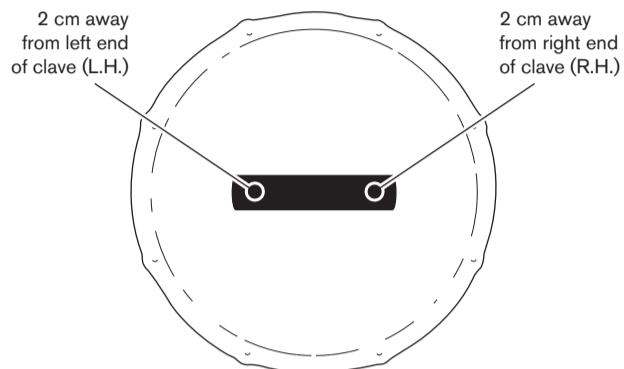

b. 192 x 56

R.H. *f*

L.H.

SECTION F

Rest while Percussion 2 and Percussion 4 play.

While holding a soft yarn mallet in each hand, sit still and silently with one's hands resting on the top head of the floor tom.

After forty bars, silently put down the soft down yarn mallet in one's right hand and replace it with the drum stick, while continuing to hold the other yarn mallet in one's left hand. Rest one's hands on the top head of the floor tom, and sit still and silently once more.

b. 248 x 64

SECTION G

All performers rest.

While holding the drum stick in one's right hand and the soft yarn mallet in one's left hand, sit still and silently with one's hands resting on the top head of the floor tom.

b. 312 x 16

SECTION H

With Percussion 4.

Side stick the tea towel-covered rim of the floor tom using the drum stick held in one's right hand. On alternate beats, beat the half-way point of the drum stick with the soft yarn mallet held in one's left hand.

Release each stick immediately after each impact so that the drum stick does not make contact with the tea towel covered-rim of the floor tom when it is hit with the yarn mallet. Ensure the base of the drum stick firmly touches the centre of the floor tom's tea-towel covered top head throughout the section, so that the vibrations from the yarn mallet beating the drum stick resonate through the floor tom.

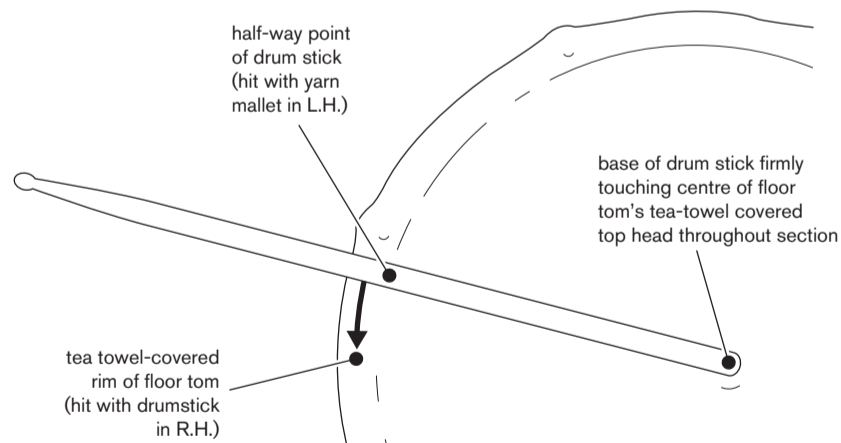

b. 328 x 48

R.H. *p*

L.H.

ENDING

On bar 374 (the penultimate bar of Section H), a recorded voice on the audio guide track announces "silence in..." over the metronome, and on bar 375 (the final bar of Section H), the voice gives a one bar count in to bar 376, where Percussion 1 and Percussion 4 suddenly stop playing. Here, one should sit still and silently with one's hands resting on the top head of the floor tom while only the metronome plays for a final sixteen bars. When the metronome stops, the piece has finished and the performers may relax.

PERCUSSION QUARTET

PART FOR PERCUSSION 2 (PREPARED ACOUSTIC GUITAR)

Paul McGuire

♩ = 140

PRECISE AND MECHANICAL, AS IF PLAYED BY A DRUM MACHINE.

THE PERFORMERS SHOULD BE AS EXPRESSIONLESS AND AS MOTIONLESS AS POSSIBLE THROUGHOUT.

BEGINNING

An engineer off stage should begin the piece by triggering the performers' audio guide track.

The piece starts with sixteen bars where all performers are silent, while the metronome plays on the audio guide track through their earphones. Here, one should sit still with one's hands resting on the guitar. On bar 15, a recorded voice on the audio guide track announces "Section A in..." over the metronome, and on bar 16 the voice gives a one bar count in to bar 17, where Section A begins. All subsequent sections are cued in this way.

SECTION A

With Percussion 3.

Tap on the centre of the adhesive-tack mute with the pads of one's left and right forefingers. Releasing the pad of one's forefinger from the adhesive-tack mute produces a sound. Therefore, one should precisely synchronise the releasing of the pad of one forefinger with the tapping of the other.

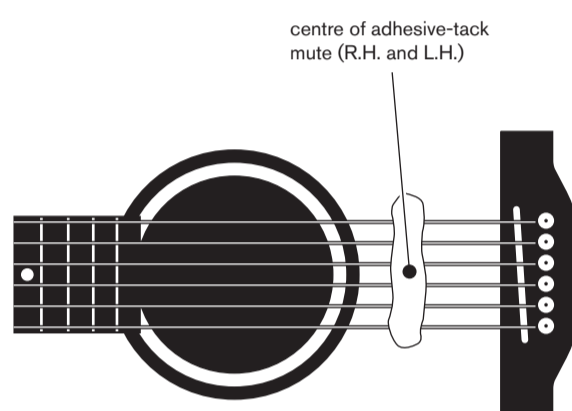

b. 17 x 48

SECTION B

With Percussion 3.

Tap on string I, at the half-way point between the adhesive-tack mute and the bridge with the fleshy tips of one's left and right forefingers.

Releasing the pad of one's forefinger from string I produces a sound. Therefore, one should precisely synchronise the releasing of the pad of one forefinger with the tapping of the other.

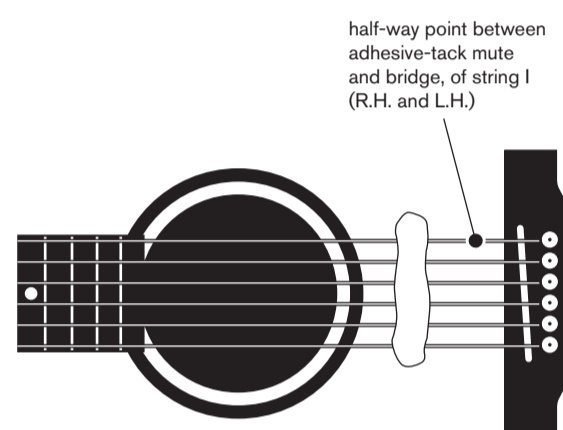

b. 65 x 48

SECTION C

With Percussion 3.

Tap on the saddle, ca. 1 cm above the end of string I with the fleshy tips of one's left and right forefingers.

Releasing the tip of one's forefinger from the upper saddle may produce a slight sound. Therefore, one should precisely synchronise the releasing of the tip of one forefinger with the tapping of the other.

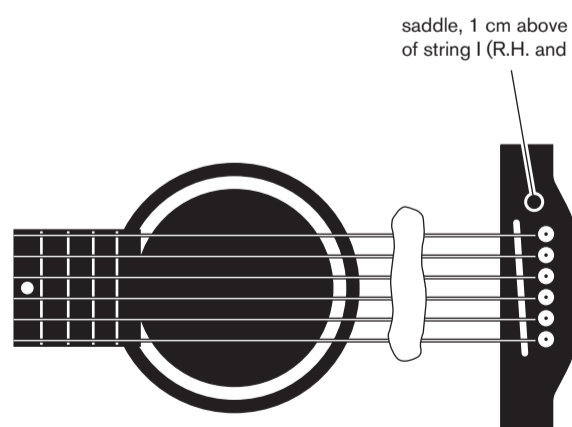

b. 113 x 23

SECTION D

With Percussion 4 and, initially, Percussion 3.

Tap on the belly of guitar, ca. 3 cm to the lower-right of the saddle with the pad of one's right forefinger, and on the saddle itself, ca. 1 cm above the end of string I with the pad of one's left forefinger.

Releasing the pad of one's right forefinger from the belly, and the pad of one's left forefinger from the upper saddle will both produce a sound. Therefore, one should precisely synchronise the releasing of the pad of one forefinger with the tapping of the other.

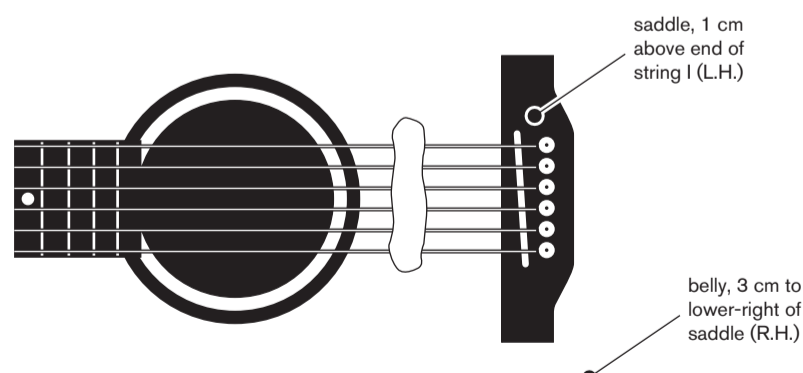

b. 136 x 56

PART FOR PERCUSSION 2 (PREPARED ACOUSTIC GUITAR)

SECTION E

Rest while Percussion 1 and Percussion 3 play.

Sit still and silently with one's hands resting on the guitar.

After forty bars, silently pick up a pair of plectrums, holding one in each hand. Rest one's hands on the guitar, and sit still and silently once more.

Hold each plectrum with three fingers and a thumb, with the base facing downwards.



SECTION F

With Percussion 4.

Tap on the saddle, ca. 1 cm above the end of string I with the base of the plectrums.

Hold the plectrums as before. This ensures each will be firm upon impact with the upper saddle, and will therefore produce a sound with a strong bass presence. Releasing a plectrum from the upper saddle should not produce a noticeable sound, and so there is no need to precisely synchronise the release of one plectrum with the tapping of the other.

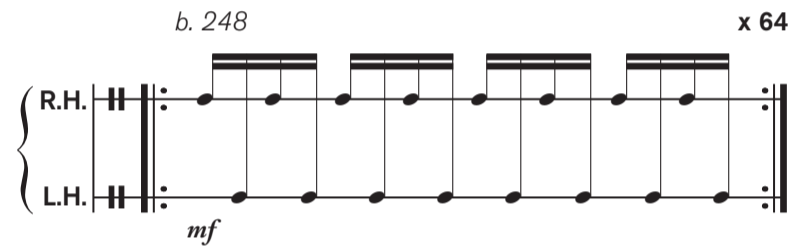
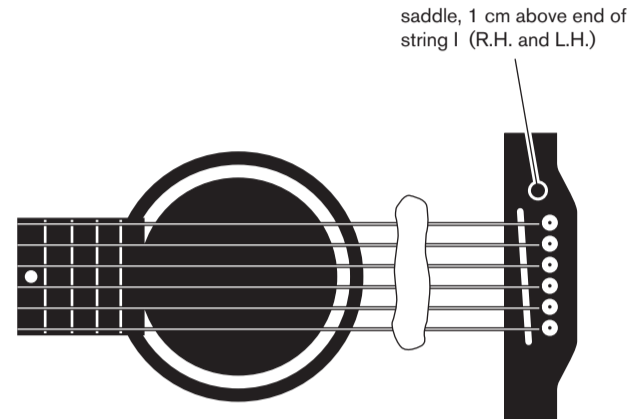

SECTION G

All performers rest.

Sit still and silently with one's hands resting on the guitar.



SECTION H

Rest while Percussion 1 and Percussion 4 play.

Sit still and silently with one's hands resting on the guitar.



ENDING

On bar 374 (the penultimate bar of Section H), a recorded voice on the audio guide track announces "silence in..." over the metronome, and on bar 375 (the final bar of Section H), the voice gives a one bar count in to bar 376, where Percussion 1 and Percussion 4 suddenly stop playing. Here, one should sit still and silently with one's hands resting on the guitar while only the metronome plays for a final sixteen bars. When the metronome stops, the piece has finished and the performers may relax.

PERCUSSION QUARTET

PART FOR PERCUSSION 3 (PREPARED ACOUSTIC GUITAR)

Paul McGuire

♩ = 140

PRECISE AND MECHANICAL, AS IF PLAYED BY A DRUM MACHINE.

THE PERFORMERS SHOULD BE AS EXPRESSIONLESS AND AS MOTIONLESS AS POSSIBLE THROUGHOUT.

BEGINNING

An engineer off stage should begin the piece by triggering the performers' in-ear audio track.

The piece starts with sixteen bars where all performers are silent, while the metronome plays on the audio guide track through their earphones. Here, one should sit still with one's hands resting on the guitar. On bar 15, a recorded voice on the audio guide track announces "Section A in..." over the metronome, and on bar 16 the voice gives a one bar count in to bar 17, where Section A begins. All subsequent sections are cued in this way.

SECTION A

With Percussion 2.

Tap on the centre of the adhesive-tack mute with the pads of one's left and right forefingers. Releasing the pad of one's forefinger from the adhesive-tack mute produces a sound. Therefore, one should precisely synchronise the releasing of the pad of one forefinger with the tapping of the other.

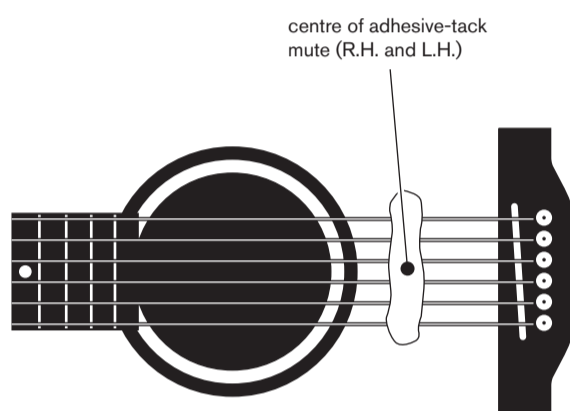

b. 17

x 48

SECTION B

With Percussion 2.

Tap on string I, at the half-way point between the adhesive-tack mute and the bridge with the fleshy tips of one's left and right forefingers.

Releasing the pad of one's forefinger from string I produces a sound. Therefore, one should precisely synchronise the releasing of the pad of one forefinger with the tapping of the other.

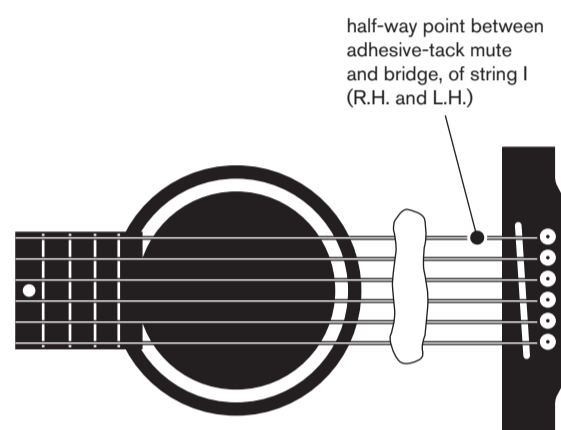

b. 65

x 48

SECTION C

With Percussion 2.

Tap on the saddle, ca. 1 cm above the end of string I with the fleshy tips of one's left and right forefingers.

Releasing the tip of one's forefinger from the upper saddle may produce a slight sound. Therefore, one should precisely synchronise the releasing of the tip of one forefinger with the tapping of the other.

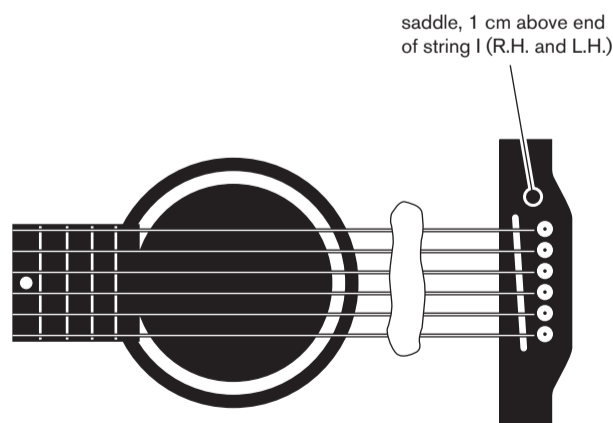

b. 113

x 23

PART FOR PERCUSSION 3 (PREPARED ACOUSTIC GUITAR)

SECTION D

With Percussion 2 and Percussion 4.

Tap on the belly of guitar, ca. 3 cm to the lower-right of the saddle with the pad of one's right forefinger, and on the saddle itself, ca. 1 cm above the end of string I with the pad of one's left forefinger. Releasing the pad of one's right forefinger from the belly, and the pad of one's left forefinger from the upper saddle will both produce a sound. Therefore, one should precisely synchronise the releasing of the pad of one forefinger with the tapping of the other.

After twenty bars, gradually decrescendo from *f* to *ppp* over the following twenty bars.

Then stop, pick up a plectrum with one's right hand and sit still and silently with one's hands resting on the guitar. Hold the plectrum the standard way, with the tip facing downwards.

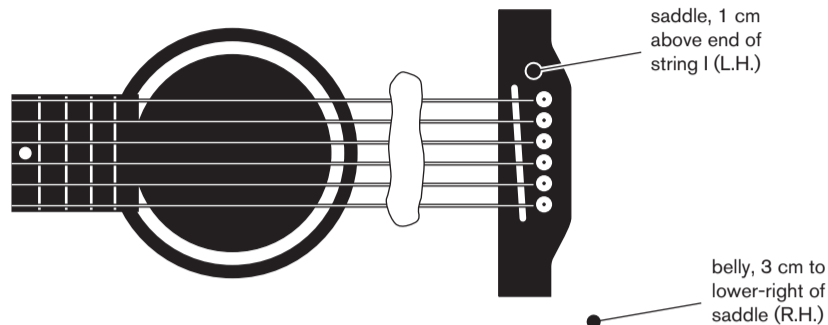

b. 136
x 20
b. 148
x 20
b. 168
x 16

R.H. RELEASE TAP

L.H. RELEASE TAP

f *f* *ppp*

Gradually decrescendo over twenty bars.

SECTION E

With Percussion 1.

While muting string I with the fleshy tip of one's left forefinger, ca. 1 cm behind the adhesive-tack mute, pluck string I, ca. 2 cm in front of the bridge using the plectrum held in one's right hand.

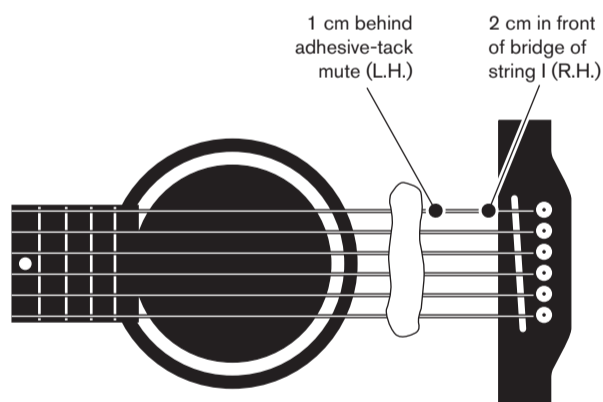

b. 192 x 56

R.H. UP-STROKE DOWN-STROKE

f

SECTION F

Rest while Percussion 2 and Percussion 4 play.

Sit still and silently with one's hands resting on the guitar.

b. 248 x 64

SECTION G

All performers rest.

Sit still and silently with one's hands resting on the guitar.

b. 312 x 16

SECTION H

Rest while Percussion 1 and Percussion 4 play.

Sit still and silently with one's hands resting on the guitar.

b. 328 x 48

ENDING

On bar 374 (the penultimate bar of Section H), a recorded voice on the audio guide track announces "silence in..." over the metronome, and on bar 375 (the final bar of Section H), the voice gives a one bar count in to bar 376, where Percussion 1 and Percussion 4 suddenly stop playing. Here, one should sit still and silently with one's hands resting on the guitar while only the metronome plays for a final sixteen bars. When the metronome stops, the piece has finished and the performers may relax.

PERCUSSION QUARTET

PART FOR PERCUSSION 4 (PREPARED FLOOR TOM)

Paul McGuire

♩ = 140

PRECISE AND MECHANICAL, AS IF PLAYED BY A DRUM MACHINE.
THE PERFORMERS SHOULD BE AS EXPRESSIONLESS AND AS MOTIONLESS AS POSSIBLE THROUGHOUT.

BEGINNING

An engineer off stage should begin the piece by triggering the performers' audio guide track.

The piece starts with sixteen bars where all performers are silent, while the metronome plays on the audio guide track through their earphones. Here, one should sit still with one's hands resting on the top head of the floor tom. On bar 15, a recorded voice on the audio guide track announces "Section A in..." over the metronome, and on bar 16 the voice gives a one bar count in to bar 17, where Section A begins. All subsequent sections are cued in this way.

SECTION A

Rest while Percussion 2 and Percussion 3 play.

Sit still and silently with one's hands resting on the top head of the floor tom.

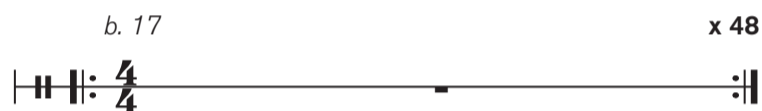

SECTION B

Rest while Percussion 2 and Percussion 3 play.

Sit still and silently with one's hands resting on the top head of the floor tom.



SECTION C

Rest while Percussion 2 and Percussion 3 play.

Sit still and silently with one's hands resting on the top head of the floor tom.



SECTION D

With Percussion 2 and, initially, Percussion 3.

Rimshot with one's forefingers on the uncovered part of the floor tom's top head, ca. 2 cm from the edge so that, with each rimshot, the pad of one's forefinger taps on the top head while the half-way point of one's forefinger simultaneously taps the rim.

Releasing the pad of one's forefinger from the top head will produce a sound. Therefore, one should precisely synchronise the release of the pad of one forefinger with the tapping of the other.

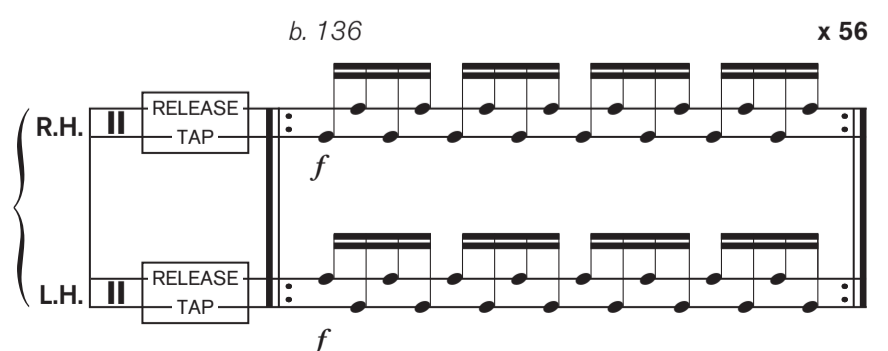
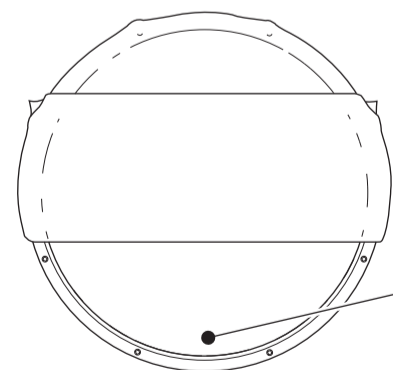

PART FOR PERCUSSION 4 (PREPARED FLOOR TOM)

SECTION E

Rest while Percussion 1 and Percussion 3 play.

Sit still and silently with one's hands resting on the top head of the floor tom.

After forty bars, silently unfold the tea towel so it covers the entirety of the floor tom's top head. Rest one's hands on the top head, and sit still and silently once more.



SECTION F

With Percussion 2.

Tap on the centre of the floor tom's tea towel-covered top head with the fleshy tips of one's forefingers.

Releasing the tip of one's forefinger from the upper saddle may produce a slight sound. Therefore, one should precisely synchronise the releasing of the tip of one forefinger with the tapping of the other.

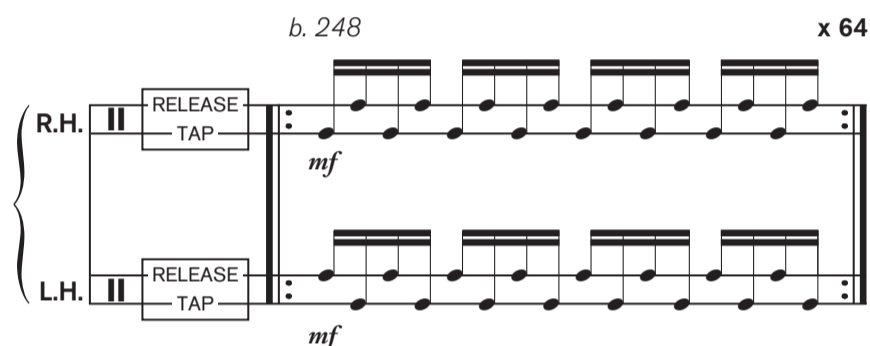
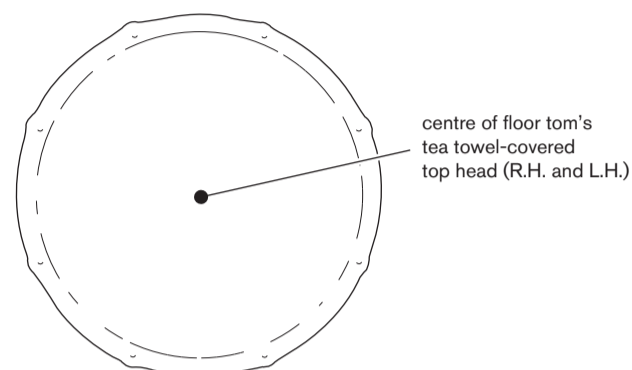

SECTION G

All performers rest.

Silently pick up the drum stick with one's right hand and the soft yarn mallet with one's left hand. Then sit still and silently with one's hands resting on the top head of the floor tom.



SECTION H

With Percussion 1.

Side stick the tea towel-covered rim of the floor tom using the drum stick held in one's right hand. On alternate beats, beat the half-way point of the drum stick with the soft yarn mallet held in one's left hand.

Release each stick immediately after each impact so that the drum stick does not make contact with the tea towel covered-rim of the floor tom when it is hit with the yarn mallet. Ensure the base of the drum stick firmly touches the centre of the floor tom's tea towel-covered top head throughout the section, so that the vibrations from the yarn mallet beating the drum stick resonate through the floor tom.

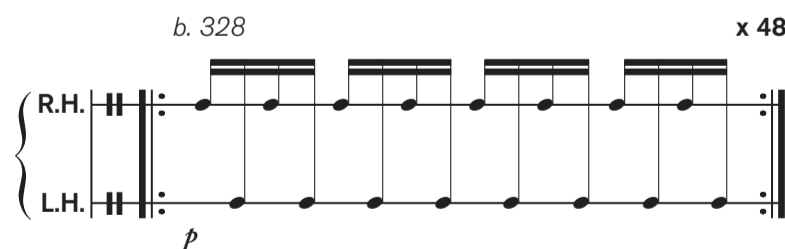
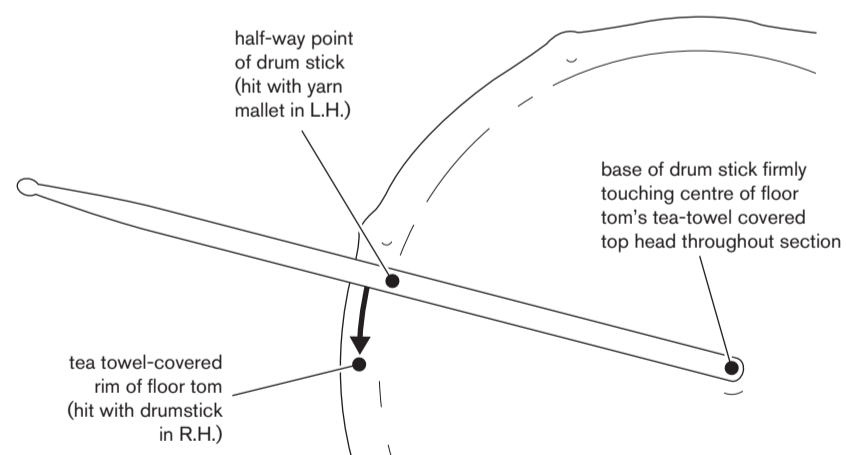

ENDING

On bar 374 (the penultimate bar of Section H), a recorded voice on the audio guide track announces "silence in..." over the metronome, and on bar 375 (the final bar of Section H), the voice gives a one bar count in to bar 376, where Percussion 1 and Percussion 4 suddenly stop playing. Here, one should sit still and silently with one's hands resting on the top head of the floor tom while only the metronome plays for a final sixteen bars. When the metronome stops, the piece has finished and the performers may relax.

SCHEMATIC

NOTES ON SCHEMATIC

This schematic should not be read as a score, but rather a brief summary of the audible events which take place during the piece.

Notation (schematic only)



Play *

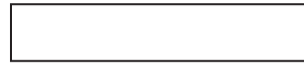

Rest

*Every played bar has the following overall rhythm:



Refer to the parts for more details.

PERCUSSION QUARTET

SCHEMATIC

Paul McGuire

$\text{♩} = 140$

PRECISE AND MECHANICAL, AS IF PLAYED BY A DRUM MACHINE.

THE PERFORMERS SHOULD BE AS EXPRESSIONLESS AND AS MOTIONLESS AS POSSIBLE THROUGHOUT.

	BEGINNING 16 BARS	SECTION A 48 BARS b. 17	SECTION B 48 BARS b. 65	SECTION C 23 BARS b. 113	SECTION D 56 BARS b. 136
PERCUSSION 1 (PREPARED FLOOR TOM)	$\frac{4}{4}$				
PERCUSSION 2 (PREPARED ACOUSTIC GUITAR)	$\frac{4}{4}$	Tap on the centre of the adhesive tack mute with the pads of one's left and right forefingers.	Tap on string I, at the half-way point between the adhesive-tack mute and the bridge with the fleshy tips of one's left and right forefingers.	Tap on the saddle, ca. 1 cm above the end of string I with the fleshy tips of one's left and right forefingers.	Tap on the belly of guitar, ca. 3 cm to the lower-right of the saddle with the pad of one's right forefinger, and on the saddle itself, ca. 1 cm above the end of string I with the pad of one's left forefinger.
PERCUSSION 3 (PREPARED ACOUSTIC GUITAR)	$\frac{4}{4}$	<i>f</i>	<i>f</i>	<i>mf</i>	<i>f</i>
		Tap on the centre of the adhesive tack mute with the pads of one's left and right forefingers.	Tap on string I, at the half-way point between the adhesive-tack mute and the bridge with the fleshy tips of one's left and right forefingers.	Tap on the saddle, ca. 1 cm above the end of string I with the fleshy tips of one's left and right forefingers.	Tap on the belly of guitar, ca. 3 cm to the lower-right of the saddle with the pad of one's right forefinger, and on the saddle itself, ca. 1 cm above the end of string I with the pad of one's left forefinger.
PERCUSSION 4 (PREPARED FLOOR TOM)	$\frac{4}{4}$				<i>f</i>
					Rimshot with one's forefingers on the uncovered part of the floor tom's top head, ca. 2 cm from the edge so that, with each rimshot, the pad of one's forefinger taps on the top head while the half-way point of one's forefinger simultaneously taps the rim.



	SECTION E 56 BARS b. 192	SECTION A 48 BARS b. 248	SECTION G 16 BARS b. 312	SECTION H 48 BARS b. 328	ENDING 8 BARS b. 376
PERC. 1 (PREP. F. T.)	Beat the curved surface of the clave, ca. 2 cm away from both ends, on the tea-towel covered top head of the floor tom with the soft yarn mallets.			Side stick the tea towel-covered rim of the floor tom using the drum stick held in one's right hand. On alternate beats, beat the half-way point of the drum stick with the soft yarn mallet held in one's left hand.	
PERC. 2 (PREP. AC. GTR.)		Tap on the saddle, ca. 1 cm above the end of string I with the base of two plectrums.		<i>p</i>	
PERC. 3 (PREP. AC. GTR.)		<i>mf</i>			
	While muting string I with the fleshy tip of one's left forefinger, ca. 1 cm behind the adhesive-tack mute, pluck string I, ca. 2 cm in front of the bridge using the plectrum held in one's right hand.				
PERC. 4 (PREP. F. T.)	<i>f</i>	Tap on the centre of the floor tom's tea towel-covered top head with the fleshy tips of one's forefingers.		Side stick the tea towel-covered rim of the floor tom using the drum stick held in one's right hand. On alternate beats, beat the half-way point of the drum stick with the soft yarn mallet held in one's left hand.	
		<i>mf</i>		<i>p</i>	